

Threaded stud without flange

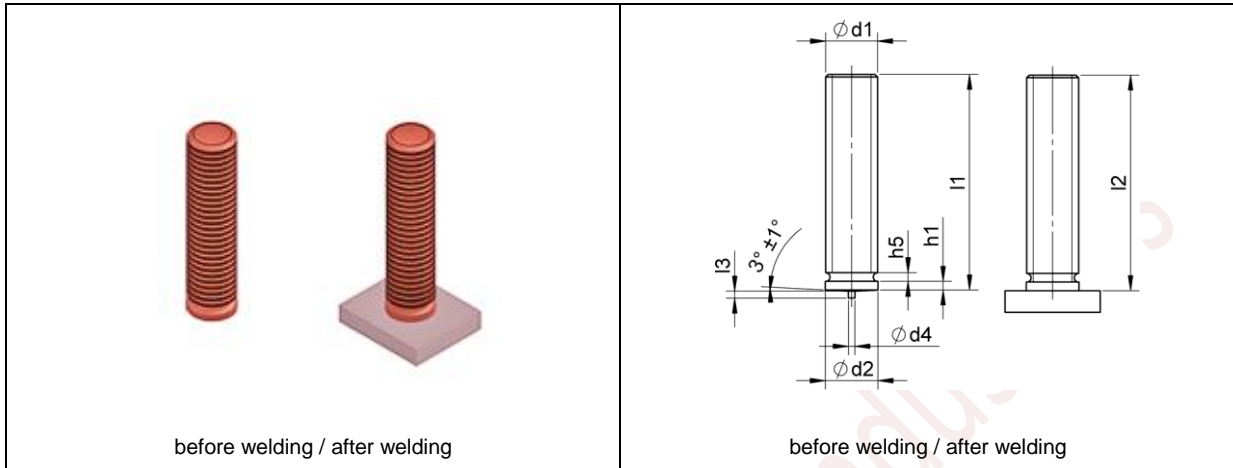

Dimensions							
d1	l1 +0.6	d2 +0.1	d4 ±0.08	l3 ±0.05	h5 max.	h1	l2
M3	6-30	3	0.6	0.55	0.6	0.7-1.4	≈ l1-0.3
M4	6-40	4	0.65	0.55	0.6	0.7-1.4	≈ l1-0.3
M5	6-45	5	0.75	0.8	1.0	0.7-1.4	≈ l1-0.3
M6	8-60	6	0.75	0.8	1.0	0.7-1.4	≈ l1-0.3
M8	10-60	8	0.75	0.85	1.5	0.8-1.4	≈ l1-0.3
M10	12-60	10	0.75	0.75	3	1.2-1.6	≈ l1-0.3